

DHB Series

DHB 330A D70

Technical datasheet



Dereike blower performance curves

Vacuum selection diagram curve

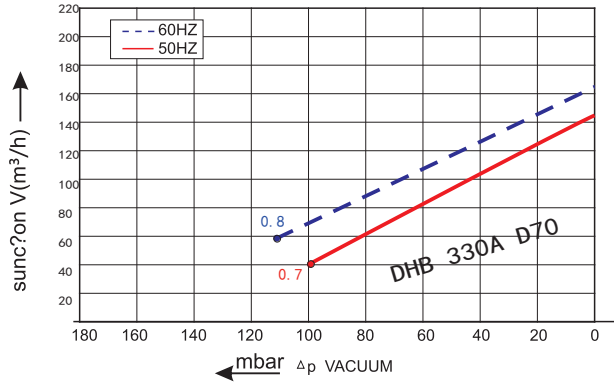

Compressor selection diagram curve

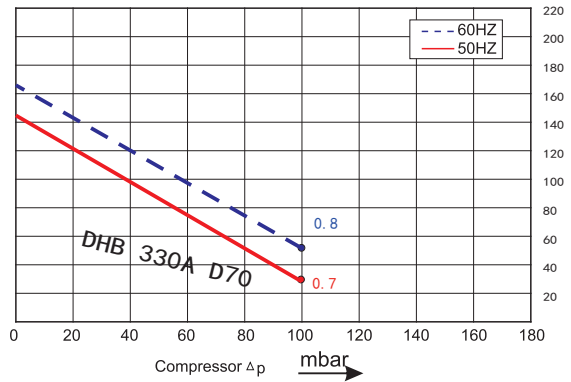

Dereike blower installation drawing

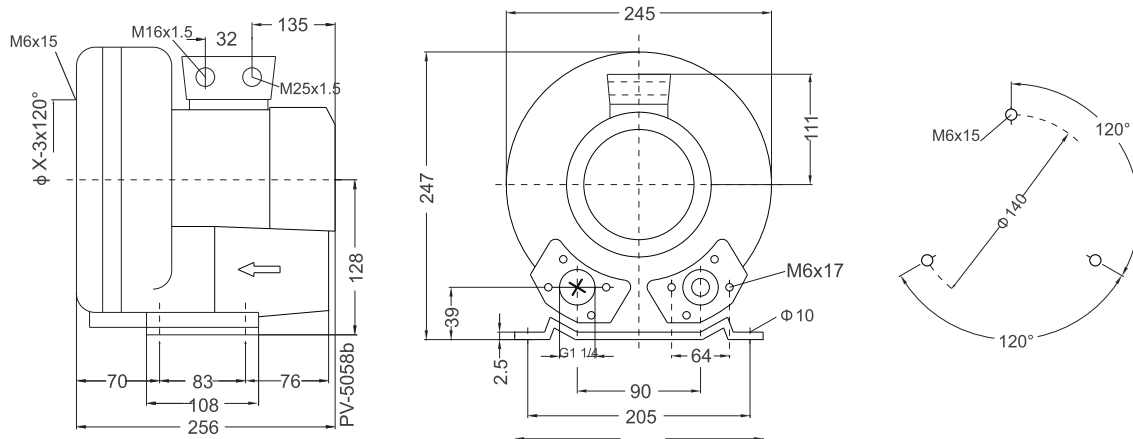

Dereike blower parameter

Model	Frequency	Output	Voltage	Current	Airflow	Pressure		Noise	Weight
						vacuum mbar	compressor mbar		
DHB 330A D70	50	0.7	200-240△	4.8	145	-100	100	53	13
	60	0.8	220-275△	4.1	165	-110	100	56	13

The performance curves of Dereike blower is tested through below ways:

Under one atmospheric pressure, suck 15°C air and then you can calculate the data, of course allow 10% difference, and when the sucked air and surroundings temperature are not higher than 25°C, you still can get total pressure difference as the curves shows.