

DHB Series

DHB 720C 4D3

Technical datasheet



Dereike blower performance curves

Vacuum selection diagram curve

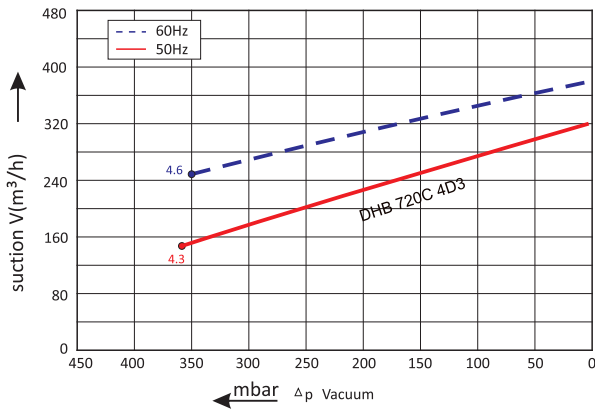

Compressor selection diagram curve

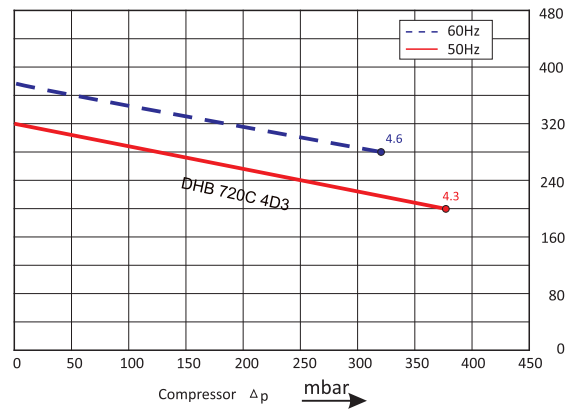

Dereike blower installation drawing

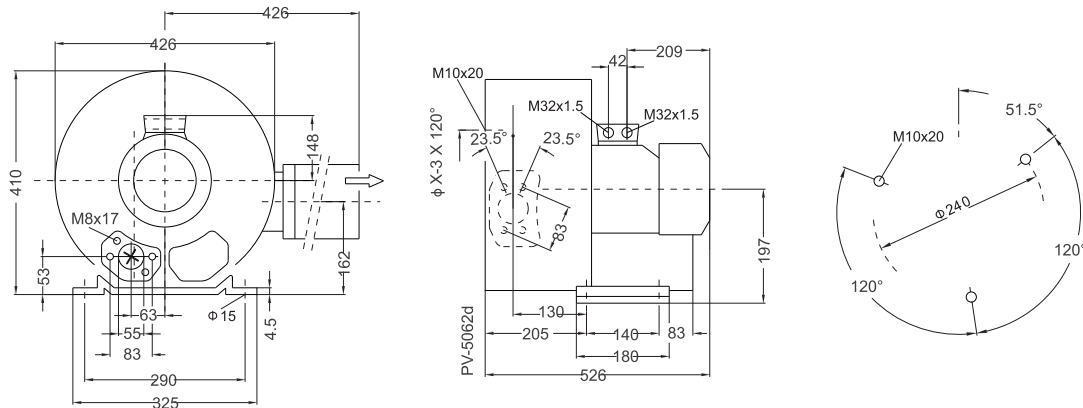

Dereike blower installation parameter

Model	Frequency	Output	Voltage	Current	Airflow	Pressure		Noise	Weight
						vacuum mbar	compressor mbar		
DHB 720C 4D3	50	4.3	345-415△/600-690Y	10.0△/5.2Y	320	-360	380	73	54
	60	4.8	380-480△/660-720Y	10.4△/6.0Y	385	-350	320	76	54

The performance curves of Dereike blower is tested through below ways:

Under one atmospheric pressure, suck 15°C air and then you can calculate the data, of course allow 10% difference, and when the sucked air and surroundings temperature are not higher than 25°C, you still can get total pressure difference as the curves shows.