

DHB Series

DHB 210A D37

Technical datasheet



Dereike blower performance curves

Vacuum selection diagram curve

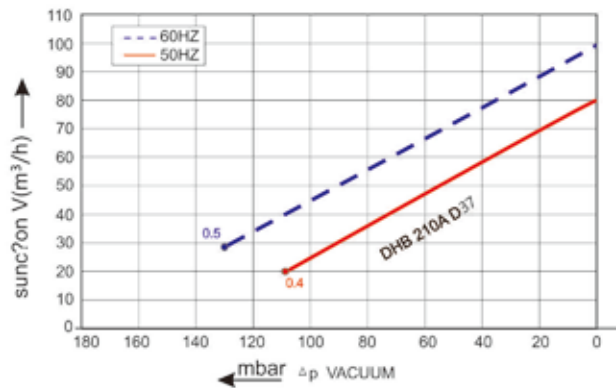

Compressor selection diagram curve

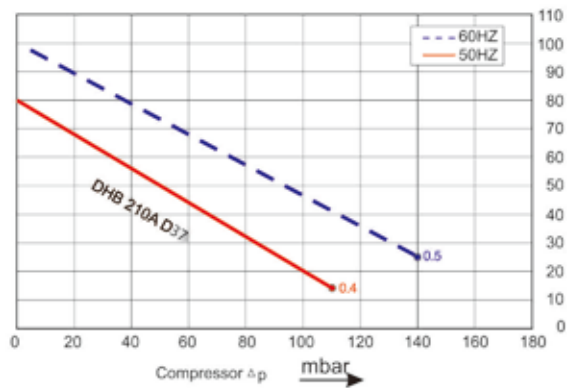

Dereike blower installation drawing

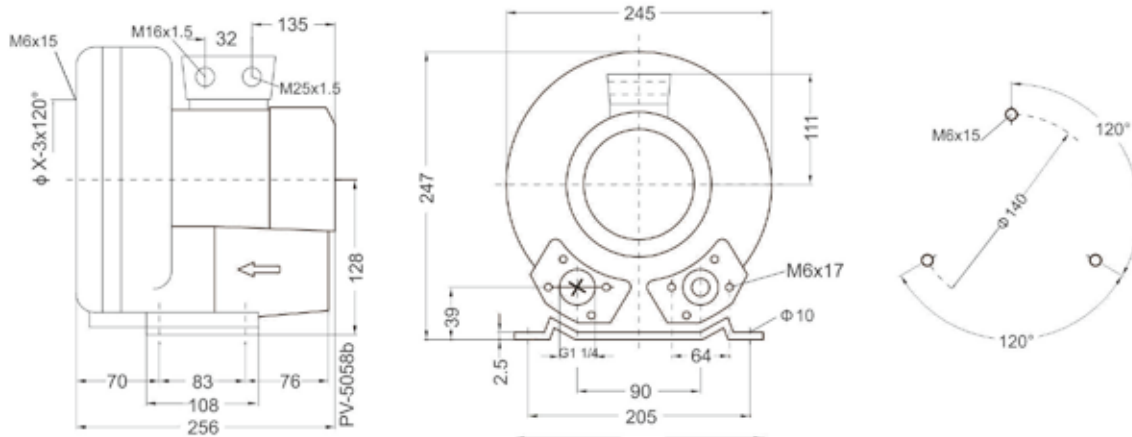

Dereike blower parameter

Model	Frequency	Output	Voltage	Current	Airflow	Pressure		Noise	Weight
						vacuum mbar	compressor mbar		
	HZ	KW	V	A	m³/h			dB(A)	
DHB 210A D37	50	0.4	200-240□	2.7□	80	-110	110	53	11
	60	0.5	220-275□	3.2□	98	-130	140	56	11

The performance curves of Dereike blower is tested through below ways:

Under one atmospheric pressure, suck 15°C air and then you can calculate the data, of course allow 10% difference, and when the sucked air and surroundings temperature are not higher than 25°C, you still can get total pressure difference as the curves shows.